

SERIES 1100 MEDIA FILTERS



FLOW-GUARD



Filtration Products

Media Filters

Media Filters

Flow-Guard Media Filters provide superior filtration in any irrigation application. Utilizing three-dimensional filtration through a media bed with large surface area has proven to be the most effective and reliable way to remove both organic and inorganic contaminant loads from your irrigation source water. So whether you're pumping surface water or ground water, Flow-Guard Media Filters will help insure years of efficient trouble-free irrigation.

Durable Stainless Steel Construction

Flow-Guard utilizes stainless steel throughout the tank construction, including the underdrain's wedge-wire elements and lateral arms. Stainless steel is corrosion resistant and lightweight yet still has a significant strength-to-weight advantage over many other materials. The Flow-Guard underdrain has no plastic parts to break or cross-thread and no false or epoxy cake bottom to damage or break due to hydraulic stress. Durable all stainless steel construction encourages a lifetime of reliable service.

Increased Backwashing Efficiency

A unique Flow-Balanced underdrain is the key to Flow-Guard's impressive backwash efficiency. The underdrain has multiple ports evenly distributed beneath the media bed. The corresponding flow "zones" provide a uniform lift and cleansing of the entire media bed, enabling shorter, less frequent backwash cycles, lower energy costs and more efficient use of your irrigation water.

Less Maintenance

Flow-Guard Media Filters deliver reliable, low maintenance filtration. Simple, easy to follow seasonal start-up and shut-down procedures help to ensure trouble-free operation throughout the growing season. The Flow-Guard underdrain system is easily serviceable through the top and bottom access ports.

Flow-Balanced Underdrain

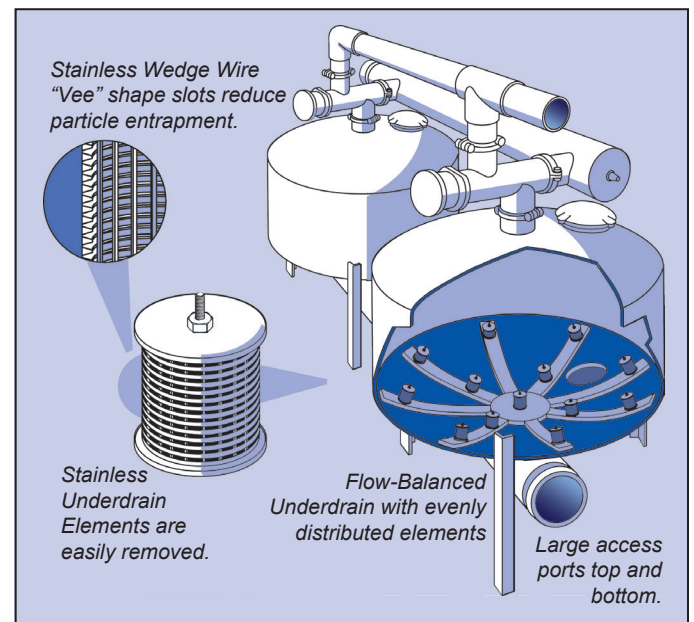

SPECIFICATIONS

FILTRATION

The irrigation source water is pressurized and introduced into the top of the media tanks. A diffusion plate in the top throat of the tank serves to reduce water velocity and distribute the water evenly across the top of the media bed. The media bed is a layer of size-graded crushed silica sand about 19" in depth. The contaminants in the water are captured in the media bed and filtered water passes into the discharge manifold at the bottom of the tanks.

Sand media filters are effective at filtering in both organic and inorganic contaminants. The large size and three-dimensional nature of a media bed provides more surface area and has greater holding capacity than many other types of filters.

BACKWASH

The key to superior media filtration is the effective removal of the captured contaminants from the media bed, commonly referred to as "backwashing". Located in the bottom of every Flow-Guard Media Filter is a highly engineered underdrain system that is designed to perform two functions. First, it must not allow media to pass through the filters during filtration. Second, during the backwash operation it must allow flush-water to be evenly distributed throughout the entire media bed, with no pockets or dead spots. This insures that the media is lifted and uniformly rinsed free of contaminants in an efficient manner.

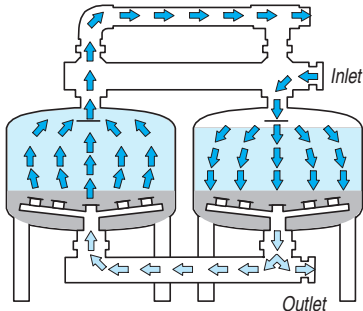
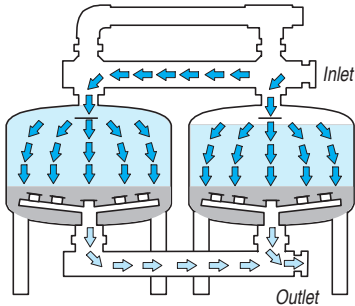

Specification and Engineering Data (Standard)

Model No.	Flow Rate - Standard		Flow Rate - Metric		Minimum Backwash Flow		Filtration Area Ft ²	Pad Size (in) W x L	Shipping Wt lbs
	25 GPM/FT ²	17 GPM FT ²	17 L/S/M ²	11.5 L/S/M ²	GPM	LPS			
215	62	42	3.9	2.6	21	1.3	2.5	24x48	136
218	88	60	5.6	3.8	26	1.6	3.5	30x48	160
318	132	90	8.4	5.7	26	1.6	5.3	30x60	240
224	157	107	9.9	6.7	48	3.1	6.3	36x60	220
324	235	160	14.8	10.1	48	3.1	9.5	36x90	330
230	244	167	15.4	10.5	83	5.2	9.8	40x80	315
330	368	250	23.2	15.8	83	5.2	14.7	40x120	430
236	353	240	22.3	15.1	105	6.6	14.1	54x96	525
336	530	360	33.4	22.7	105	6.6	21.2	54x126	770
245	555	377	35.0	23.8	188	11.9	22.2	60x114	690
345	832	566	52.5	35.7	188	11.9	33.3	60x160	1075
445	1110	754	70.0	47.6	188	11.9	44.4	60x220	1490
545	1387	943	87.5	59.5	188	11.9	55.5	60x300	1850
645	1665	1132	105.0	71.4	188	11.9	66.6	60x350	2200
248	625	425	39.4	26.8	200	12.6	25	60x114	720
348	937	637	59.1	40.2	200	12.6	37.5	60x160	1105
448	1250	850	78.9	53.6	200	12.6	50	60x220	1520
548	1562	1062	98.5	67.0	200	12.6	62.5	60x300	1880
648	1875	1275	118.3	80.4	200	12.6	75	60x350	2230

NOTES:

Flow rates are computed at rates not in excess of 25 GPM (17 LPS) or less than 17 GPM (11.5 LPS) respectively, per square foot of media bed surface. When selecting flow rates, certain variables should be considered. The quality of the source of water will influence the frequency of backwash cycles. Excessively dirty water will increase backwash frequency, and in such conditions, flow rates should be adjusted towards the lower flow rate. Pad sizes are for filters only. Allow extra space for pumps, injectors, valves, etc. Pads should be at least 4" thick.

SPECIFICATIONS

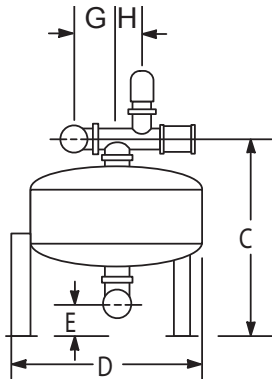
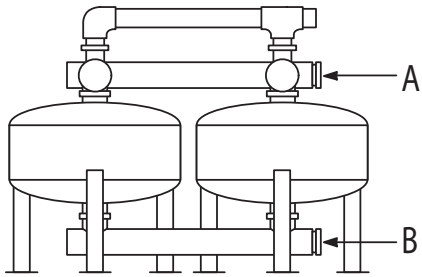

Configurations

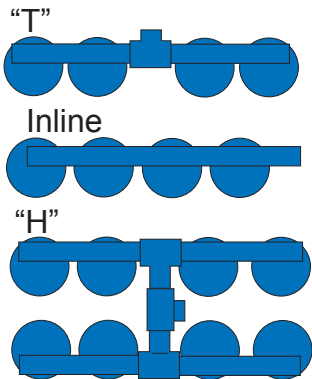

Miscellaneous Data

Standard manifold connections:	Grooved coupling
Optional flush controls:	Maxim Alextronix

Controller Specifications

With Flow-Guard's filters, a fully programmable, solid-state controller is provided. Backwash cycles may be initiated manually or automatically by pressure differential or timed intervals.

Features: Accurate timing
Models Available in 12 VDC or 24 VAC

Models: 3 - 16 Outputs

Dimensional Information (Standard)

Model No.	A Inlet Diameter	B Outlet Diameter	C	D	E	G	H
215	2	2	42.75	18	6	6 3/4	2 1/4
218	3	3	43.75	21	6	7 1/4	2 1/4
318	3	3	43.75	21	6	7 1/4	2 1/4
224	3	3	44.75	27	6	8 1/4	2 3/8
324	4	4	44.75	27	6	8 3/4	2 3/8
230	4	4	52.13	33	9.75	8 3/4	2 3/8
330	6	6	52.13	33	8.75	9 7/8	2 3/8
236	4	4	53.75	39	10.75	8 3/4	2 3/8
336	6	6	53.75	39	9.75	9 7/8	2 3/8
245	6	6	53.75	48	10.5	10 1/8	3 1/4
345	6	6	53.75	48	10.5	10 1/8	3 1/4
445	8	8	53.75	48	9.5	11 1/8	3 1/4
445T	10	10	53.75	48	10.5	10 1/8	3 1/4
545	10	10	53.75	48	8.5	12 1/4	3 1/4
545T	10	10	53.75	48	10.5	10 1/8	3 1/4
645T	10	10	53.75	48	10.5	10 1/8	3 1/4
248	6	6	58.75	51	10.5	10 1/8	3 1/4
348	6	6	58.75	51	10.5	10 1/8	3 1/4
448	8	8	58.75	51	9.5	11 1/8	3 1/4
448T	10	10	58.75	51	10.5	10 1/8	3 1/4
548	10	10	58.75	51	8.5	12 1/4	3 1/4
548T	10	10	58.75	51	10.5	10 1/8	3 1/4
648T	10	10	58.75	51	10.5	10 1/8	3 1/4

Pressure Rating

Tank Size	15 - 36 100 PSI / 7 Kg / CN ²
	45 - 48 80 PSI / 5.6 Kg / CN ²

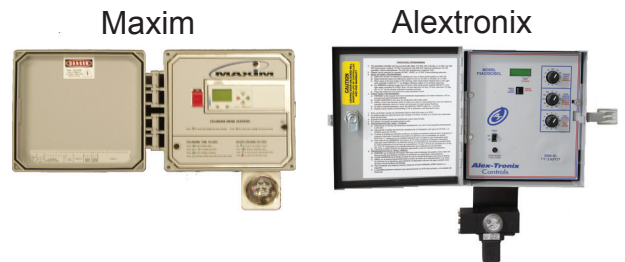

Electrical: AC/DC models are either 110 or 230 VAC 50/60 Hz or 12-15 VDC

Input: .5 amps
Output: 12 VDC or 24 VAC 2 amps
Idle Current: 38 mA

Options: Solar panel, bracket or battery for DCL models, 230-240 CVAC, 50 Hz input available.

SPECIFICATIONS

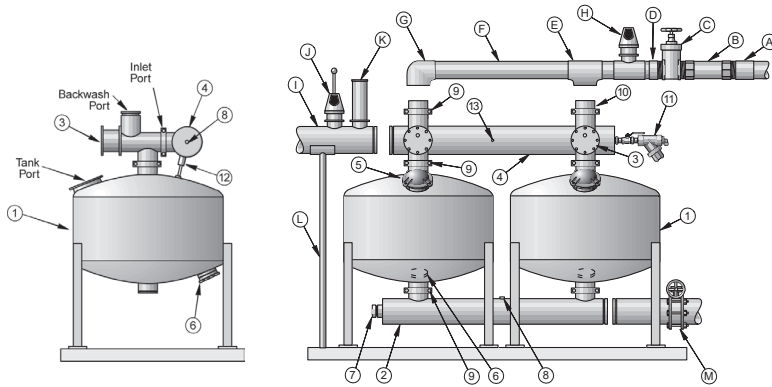

Components

1. Media Tank
2. Outlet Manifold
3. Backwash Valve
4. Inlet Manifold
5. Maway (Fill port)
6. Drain Port
7. Clean Water Access Port
8. 1/2" Access Port
9. Groove Coupling
10. PVC Groove Adapter
11. Hydraulic Charging Assembly
12. Manifold Support (48" models only)
13. 1/4 Access Port

Accessories

- A. PVC Female Adapter
- B. View Tube
- C. Backwash Throttle Valve
- D. PVC Male Adapter
- E. PVC "Tee"
- F. PVC Piping (SCD 40)
- G. PVC 90° Elbow
- H. Air & Vacuum Vent
- I. Supply System Piping
- J. Continuous Acting Air Vent
- K. Pressure Relief Valve
- L. Support
- M. On / Off Valve

Material Specifications

Media tanks, manifolds, stainless steel underdrain assembly with stainless steel wedge wire elements, are constructed using type 304 stainless steel. Optional type 316 stainless steel construction is available on request.

Backwash valves and port hole covers are manufactured from cast iron ASTM A126, Class B, with fusion epoxy coating. The valve stems, washers, nuts and bolts are manufactured from type 304 stainless steel. A PVC stem guide bushing with O-Rings is used for corrosion free operation of the backwash valve.

Media

Media Material And No.	Mean Effective Media Size	Mean Uniformity Coefficient	Equivalent Mesh Size
#20 Crushed Silica	0.48	1.50	190-250*
#16 Crushed Silica	0.68	1.50	130-180*
#12 Crushed Silica	1.05	1.50	90-130*

NOTE: *Based on GPM/Ft². Crushed granite media available upon request. Other types of media not recommended.

Gravel & Sand Requirements

Model No.	Gravel	Sand
	80 lb / 36 Kg bags	100 lb / 45 Kg bags
215	1	3
218	2	4
224	3	8
324	4	12
230	4	10
330	6	15
236	6	16
336	9	24
245	12	24
345	18	36
445	24	48
545	30	60
645	36	72
248	14	26
348	21	39
448	28	52
548	35	65
648	42	78



Valves & Castings, Inc.

Specifications subject to change without notice.

Fresno Valves & Castings, Inc.
 7736 East Springfield Avenue
 P.O. Box 40, Selma, CA 93662, U.S.A.
 (800) 333-1658
 www.fresnovalves.com

Rev. 10/17